

# Steel Disc Couplings

## RINGFEDER® TND HSH

Standard Hubs, Single-Jointed, without Spacer,  
Shaft-Hub Connection by Keyway

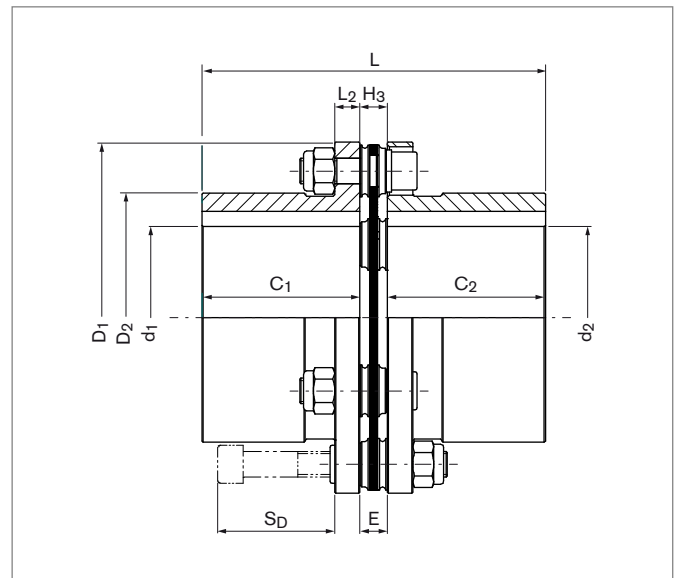
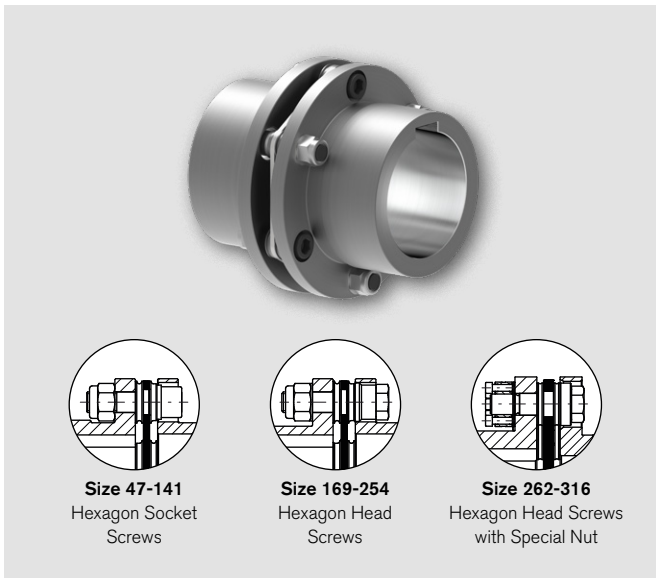

Size	T <sub>KNHD</sub> <sup>1)</sup>	T <sub>KNHT</sub> <sup>1)</sup>	n <sub>max</sub>	d <sub>pre</sub> <sup>3)</sup>	d <sub>1k;d2k</sub> max <sup>4)</sup>	C <sub>1</sub> / C <sub>2</sub>	E	H <sub>3</sub>	D <sub>1</sub>	D <sub>2</sub>	L <sub>2</sub>	L	S <sub>D</sub>	n <sub>sc</sub>
<b>HSH</b>	Nm	Nm	1/min	mm	mm	mm	mm	mm	mm	mm	mm	mm	mm	Quantity
47	170	230	8400	10	32	39,5	7,5	7,5	70,5	47	5	86,5	24	6
63	320	420	6800	14	42	45	9	9	88	62,5	8	99	32	6
82	750	1050	5400	15	55	55	10,5	10,5	116	82	10	120,5	40	6
98	1350	1750	4600	19	65	60	12	12	140,5	98	11	132	47	6
118	2400	3000	3800	25	85	75	13	13	166,5	118	12	163	55	6
141	4000	5200	3400	30	95	90	15	15	198,5	141	14	195	64	6
169	6500	8500	3000	39	115	125	21	21	238	169	16	271	81	6
205	21000	26000	2500	59	140	160	28	28	295	205	22	348	112	8
254	36000	44000	2100	79	175	200	32,5	32,5	345	254	26	432,5	133	8
262	74000	---	1800	90	180	210	34	34	420	262	32	454	137	8
316	130000	---	1500	100	215	240	47	47	510	316	38	527	172	8

To continue see next page

## Steel Disc Couplings RINGFEDER® TND HSH

Size	G <sub>WSB</sub> <sup>6)</sup>	J <sub>SB</sub> <sup>6)</sup>	C <sub>TdynHD</sub>	C <sub>TdynHT</sub>	Max. Permissible Misalignment <sup>7)</sup>					
					axial		angular		radial	
HSH	kg	10 <sup>-3</sup> kgm <sup>2</sup>	10 <sup>6</sup> Nm/rad	10 <sup>6</sup> Nm/rad	ΔK <sub>a</sub> HD	ΔK <sub>a</sub> HT	ΔK <sub>w</sub> HD	ΔK <sub>w</sub> HT	ΔK <sub>r</sub> HD	ΔK <sub>r</sub> HT
					mm	mm	Degrees	Degrees	mm	mm
47	1,3	0,5	0,173	0,184	0,5	0,3	1	0,7	---	---
63	2,6	1,6	0,281	0,312	0,5	0,4	1	0,7	---	---
82	5,6	5,9	0,637	0,743	0,7	0,4	1	0,7	---	---
98	8,8	14	1,173	1,251	1	0,6	1	0,7	---	---
118	15,4	35	2	2,082	1,2	0,8	1	0,7	---	---
141	25,9	84	2,992	3,142	1,4	0,8	1	0,7	---	---
169	50	230	5,269	6,586	1,5	1,2	1	0,7	---	---
205	97,8	700	21,848	22,285	1,1	0,6	0,5	0,4	---	---
254	171,2	1750	37,204	37,868	1,1	0,8	0,5	0,4	---	---
262	223,2	3260	46,192	---	1,6	---	0,5	---	---	---
316	384,4	8650	87,706	---	1,8	---	0,5	---	---	---

1) When selecting the size, it is essential to observe the instructions on coupling dimensioning in the document "Product Paper & Tech Paper RINGFEDER® Steel Disc Couplings". Short-term peak torque T<sub>Kmax</sub> is limited to 1.75 multiples of T<sub>KN</sub>.

3) Pre-bore has free tolerance.

4) Maximum finished bore with keyways according to DIN 6885-1.

6) Weight and mass moments of inertia for pre-bored hubs.

7) The maximum misalignment values must not apply simultaneously. The instructions on coupling dimensioning in the document "Product Paper & Tech Paper RINGFEDER® Steel Disc Couplings" are to be observed.

## Explanations

<b>T<sub>KNHD</sub></b> = Nom. transmissible torque with disc pack HD	<b>D<sub>1</sub></b> = Max. outer diameter	<b>ΔK<sub>a</sub>HD</b> = Max. permissible axial misalignment with disc pack HD
<b>T<sub>KNHT</sub></b> = Nom. transmissible torque with disc pack HT	<b>D<sub>2</sub></b> = Outer diameter hub	<b>ΔK<sub>a</sub>HT</b> = Max. permissible axial misalignment with disc pack HT
<b>n<sub>max</sub></b> = Max. rotational speed	<b>L<sub>2</sub></b> = Hub flange thickness	<b>ΔK<sub>w</sub>HD</b> = Max. permissible angular misalignment with disc pack HD
<b>d<sub>pre</sub></b> = Diameter pre-bore	<b>L</b> = Total length	<b>ΔK<sub>w</sub>HT</b> = Max. permissible angular misalignment with disc pack HT
<b>d<sub>1kmax</sub></b> = Max. bore diameter d <sub>1</sub> with keyway acc. to DIN 6885-1	<b>S<sub>D</sub></b> = Disassembly space	<b>ΔK<sub>r</sub>HD</b> = Max. permissible radial misalignment with disc pack HD
<b>d<sub>2kmax</sub></b> = Max. bore diameter d <sub>2</sub> with keyway acc. to DIN 6885-1	<b>n<sub>Sc</sub></b> = Quantity of screws	<b>ΔK<sub>r</sub>HT</b> = Max. permissible radial misalignment with disc pack HT
<b>C<sub>1</sub></b> = Guided length in hub bore	<b>G<sub>WSB</sub></b> = Weight at smallest bore diameter	
<b>C<sub>2</sub></b> = Guided length in hub bore	<b>J<sub>SB</sub></b> = Moment of inertia at smallest bore diameter.	
<b>E</b> = Distance between hubs	<b>C<sub>TdynHD</sub></b> = Dynamic torsional stiffness with disc pack HD	
<b>H<sub>3</sub></b> = Width of the disc pack	<b>C<sub>TdynHT</sub></b> = Dynamic torsional stiffness with disc pack HT	

## Ordering example

Type	Size	Disc pack	Bore diameter d <sub>1</sub>	Bore diameter d <sub>2</sub>
TND HSH	118	HD	60	80

### Technical Information

- Without further specifications, we deliver as standard: Bore tolerance H7; Keyway acc. to DIN 6885-1; Keyway width tolerance P9; Set screw per hub.
- From a peripheral speed of 30 m/s, separate balancing of the individual coupling parts is recommended.
- Without further instructions on balancing, the coupling parts are balanced individually according to DIN 21940-11 in quality G 6,3 at 1,500 1/min. The hubs are balanced half key (before grooving).

Further information on RINGFEDER® TND HSH on [www.ringfeder.com](http://www.ringfeder.com)

### Disclaimer of liability

All technical details and notes are non-binding and cannot be used as a basis for legal claims. The user is obligated to determine whether the represented products meet his requirements. We reserve the right to carry out modifications at any time in the interests of technical progress.