

# Montage, démontage, remontage

## Jeux de serrage

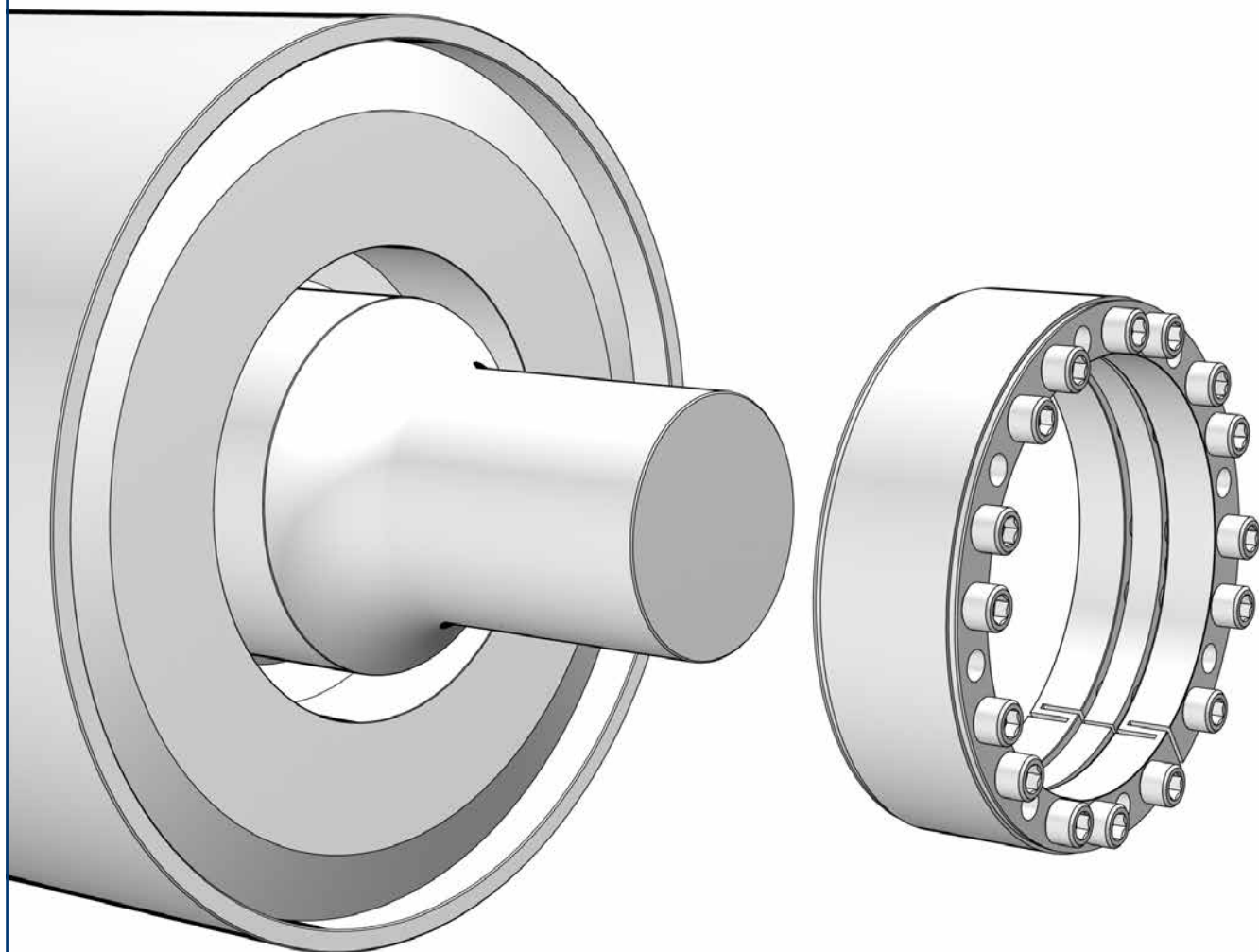

RfN 7515

**FR**

11|2016

### Consignes de sécurité

Les éléments de machine en rotation peuvent blesser les opérateurs et les techniciens de maintenance! Il convient donc:

- de couper l'entraînement avant les opérations de montage.
- de sécuriser la machine contre toute remise en marche involontaire.
- de monter tous les carters et dispositifs de protection avant la mise en marche de la machine.
- Le montage des produits RINGFEDER® ne doit être réalisé que par des techniciens qualifiés et aux fins de cas d'applications appropriées.

### Attention

- Lire attentivement les instructions de montage.
- Nous déclinons toute responsabilité en cas de non-respect des instructions de montage ou des consignes de sécurité.
- RINGFEDER® se réserve le droit de procéder à des modifications techniques destinées à améliorer les produits.
- Les éléments de serrage RINGFEDER® sont conformes à l'état actuel de la technique.

**En cas de questions et de problèmes techniques, veuillez vous adresser à nos techniciens et collaborateurs du bureau d'étude. Leurs coordonnées figurent au verso.**

### Lubrifiants appliqués

Désignation	N° CAS (ROHS)
Huile de machines Shell Omala 220	-

### Légende



Montage



Démontage



Remontage



Nettoyage



Le cas échéant, huilez légèrement le moyeu et l'arbre (ne pas utiliser d'huiles contenant du MoS2).

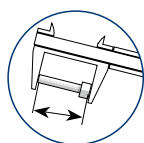

Contrôler la vis quant à d'éventuelles déformations et la remplacer le cas échéant.



Effectuer le processus décrit en procédant de manière croisée selon le nombre de fois indiqué.



Effectuer le processus décrit selon le nombre de fois indiqué.



Vérifier la profondeur de rugosité admissible.



Attention! A respecter impérativement!



Les données applicables aux couples de serrage nécessaires figurent dans le catalogue de jeux de serrage actuel. Veuillez vérifier si le constructeur de la machine/ installation a fourni des couples de serrage divergents.

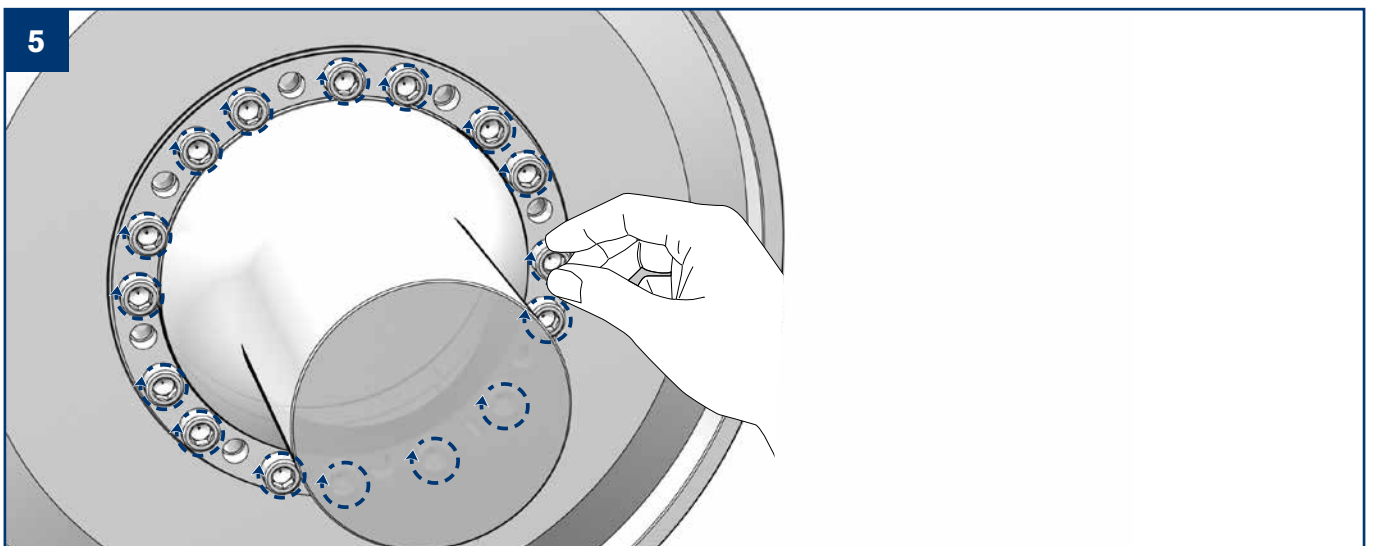
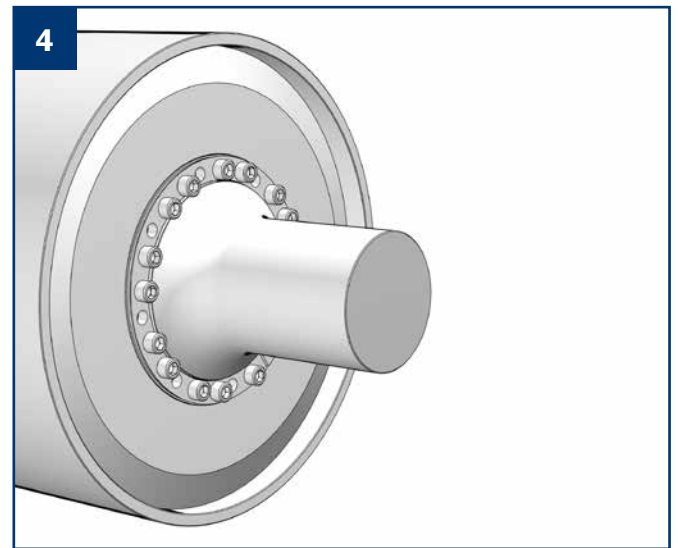
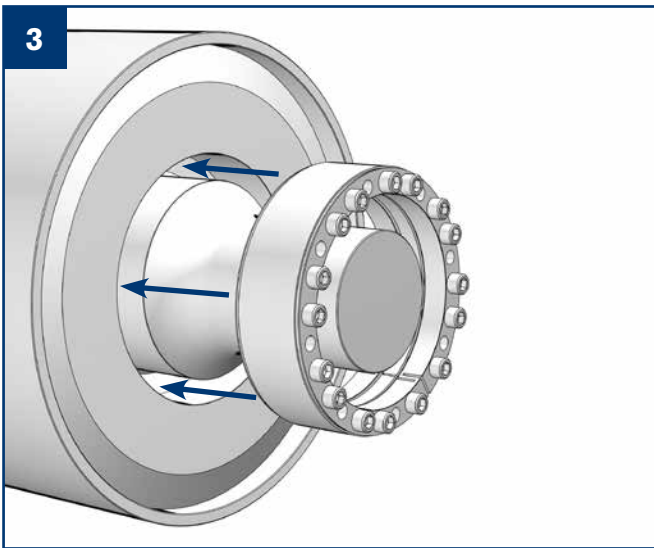
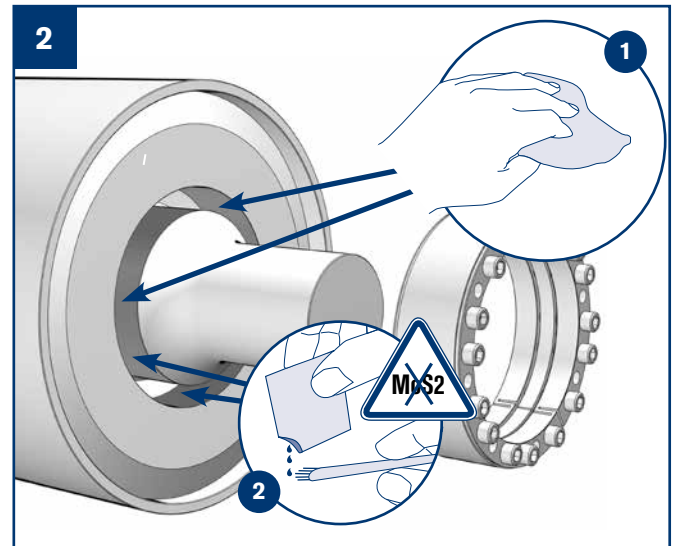
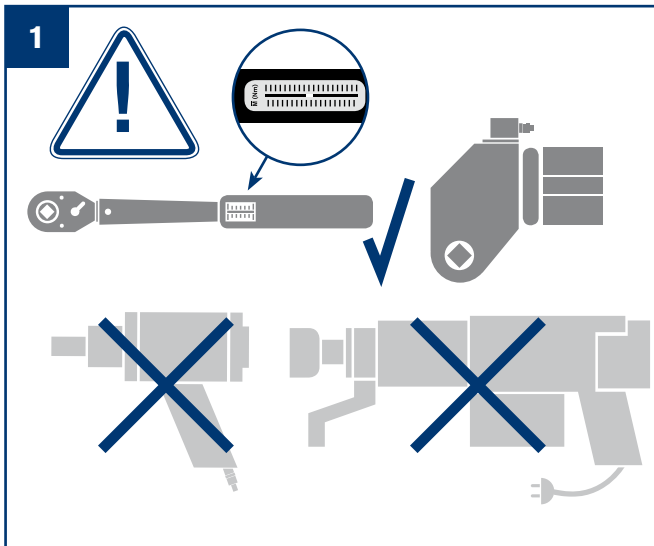

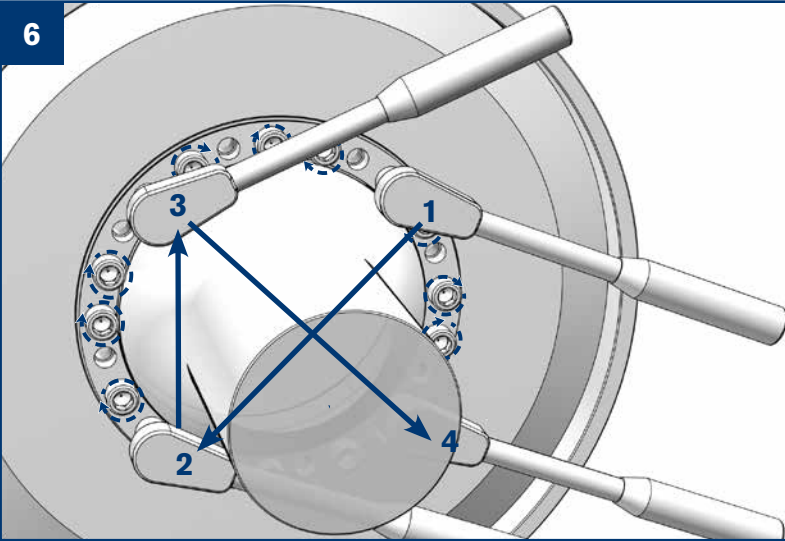

	1/3 TA
	2/3 TA
<hr/>	
	TA

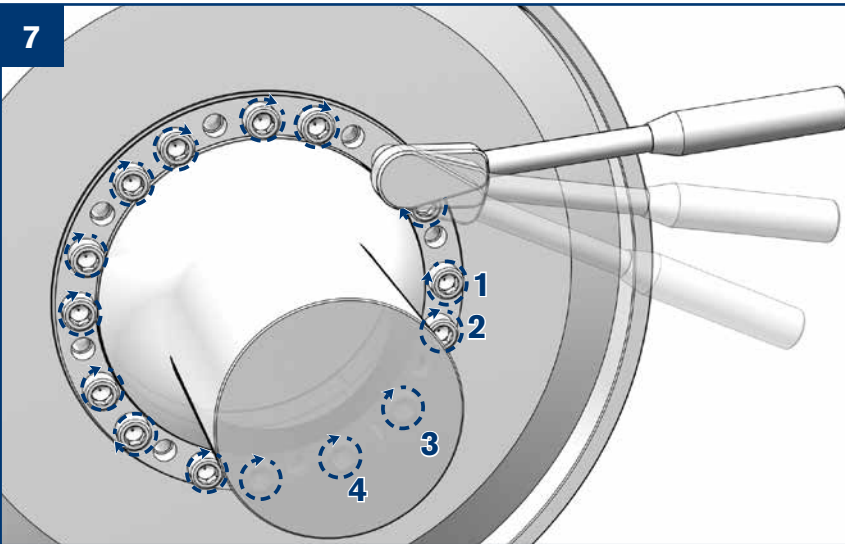

--



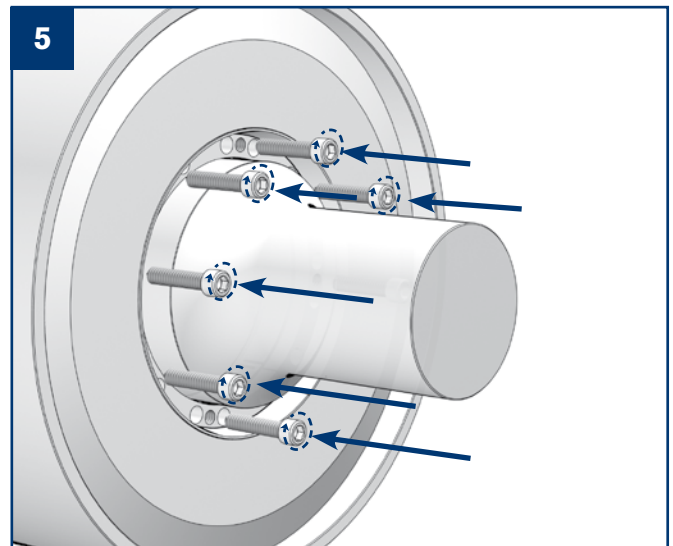
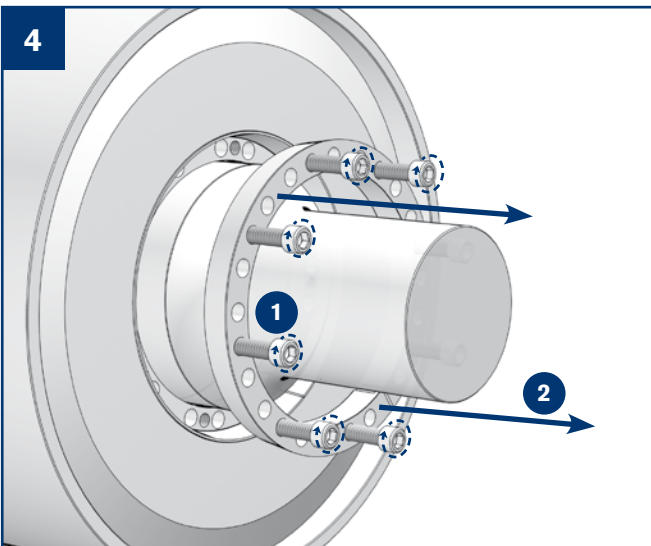
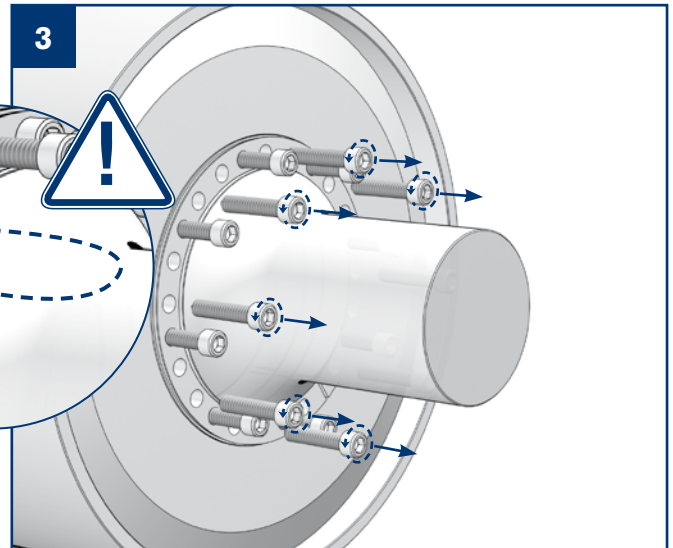
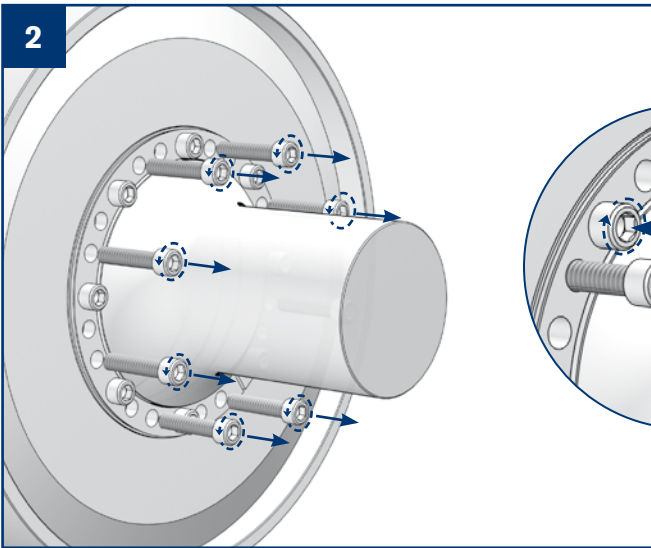
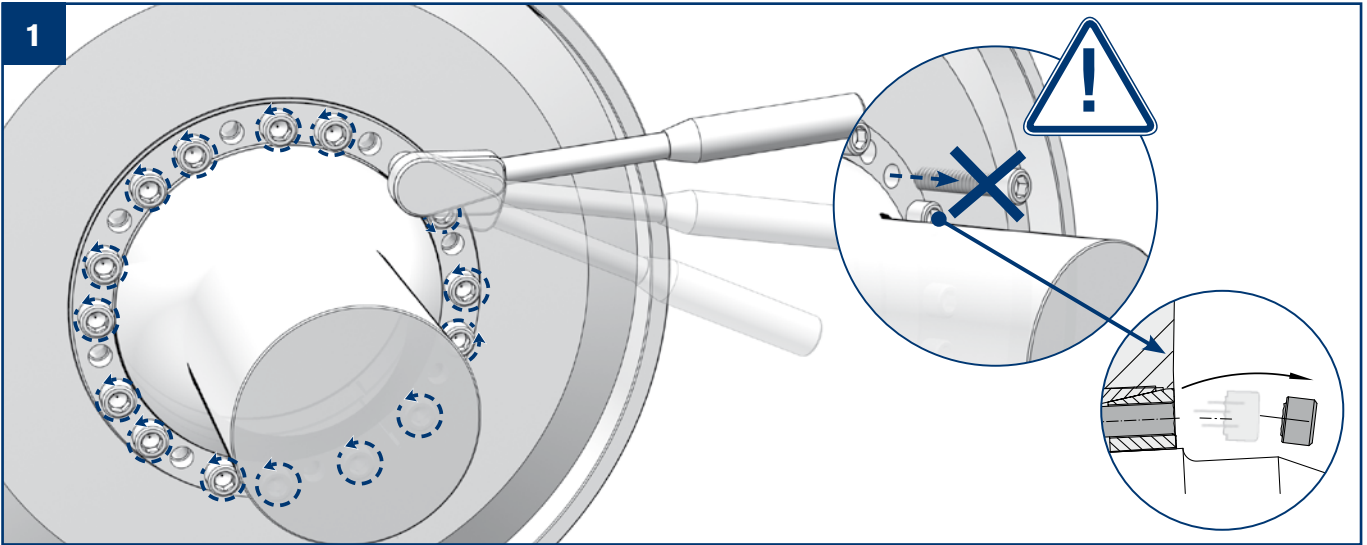



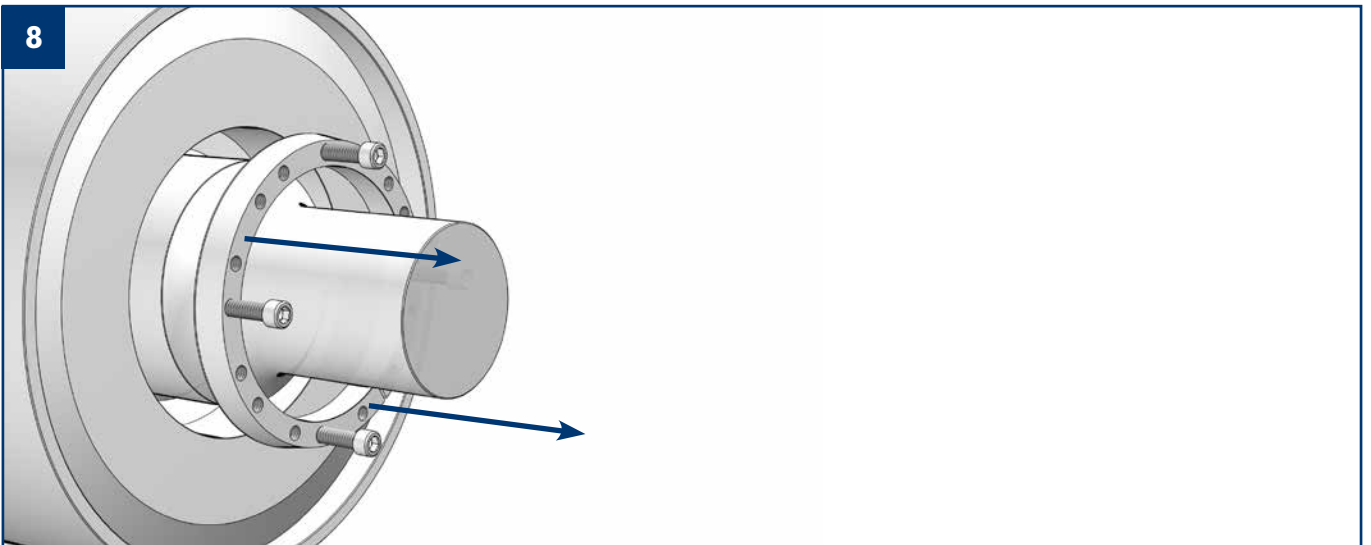
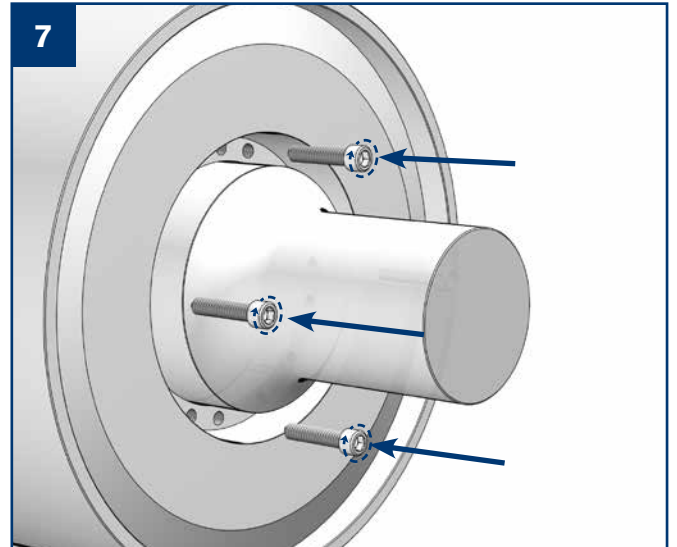
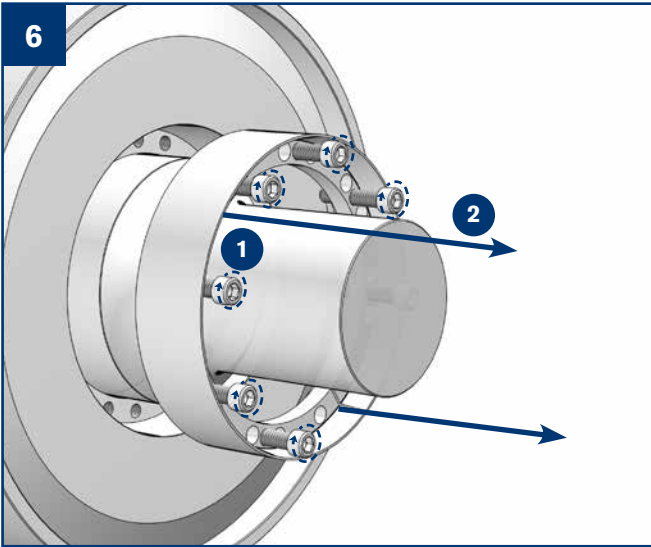

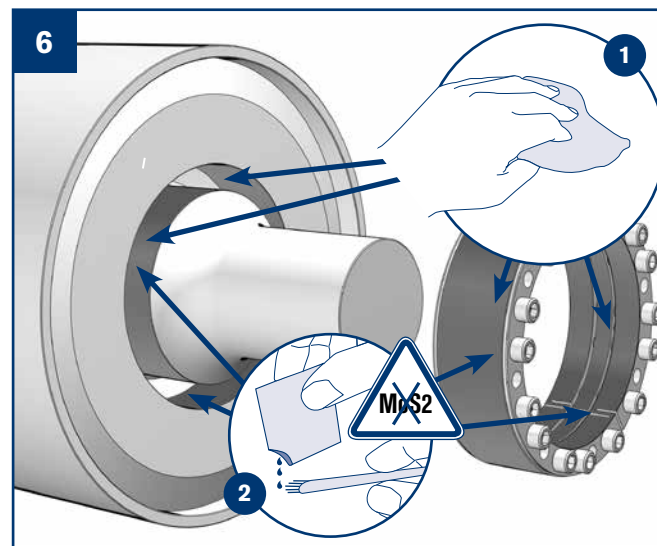
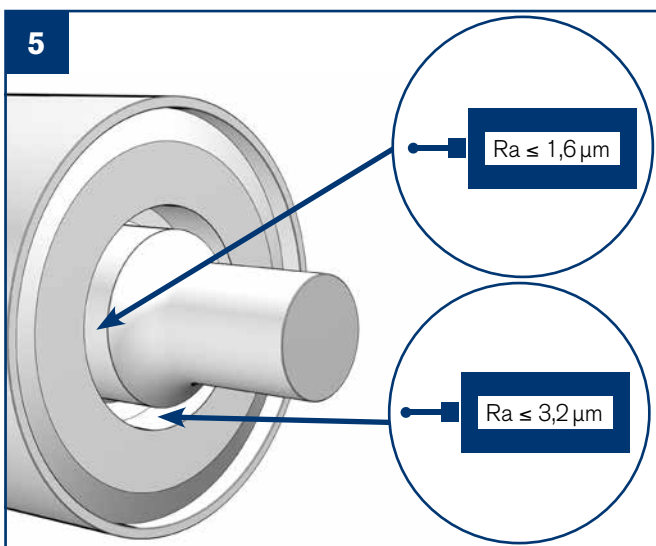
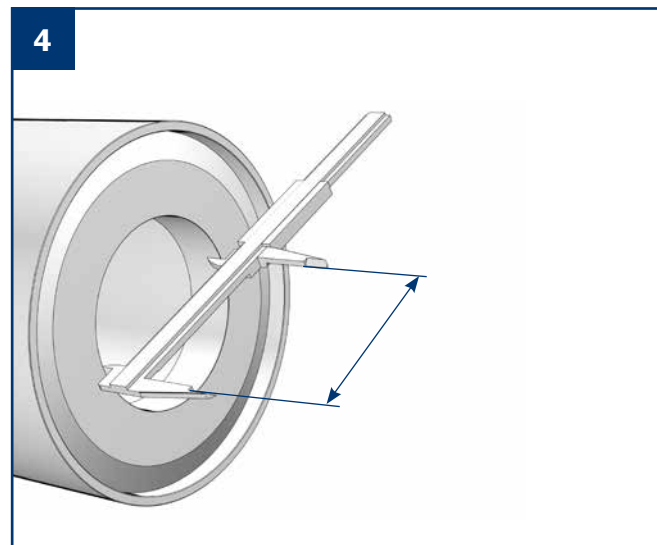
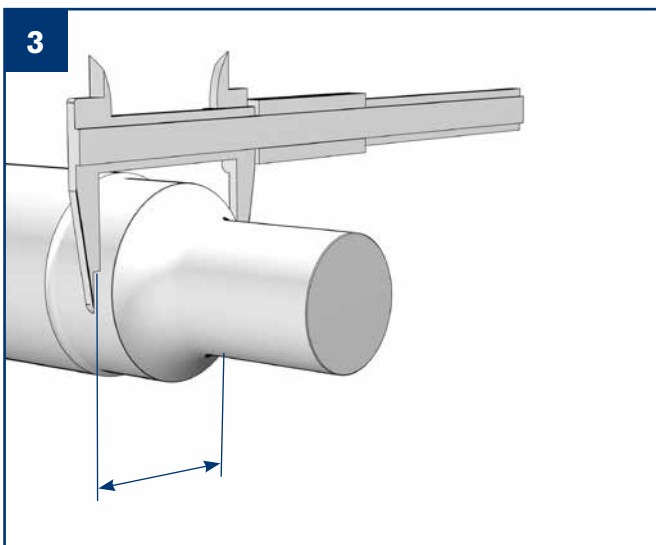
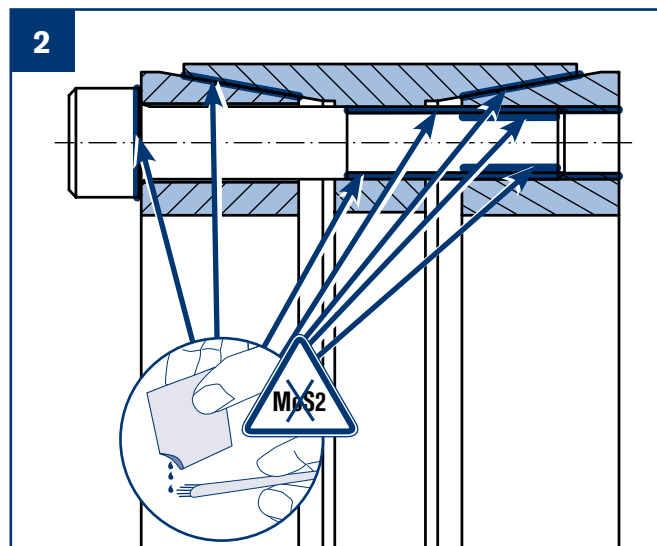
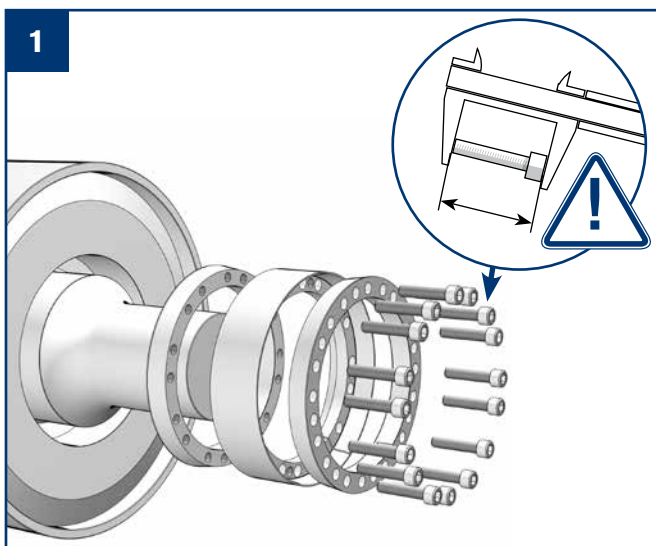

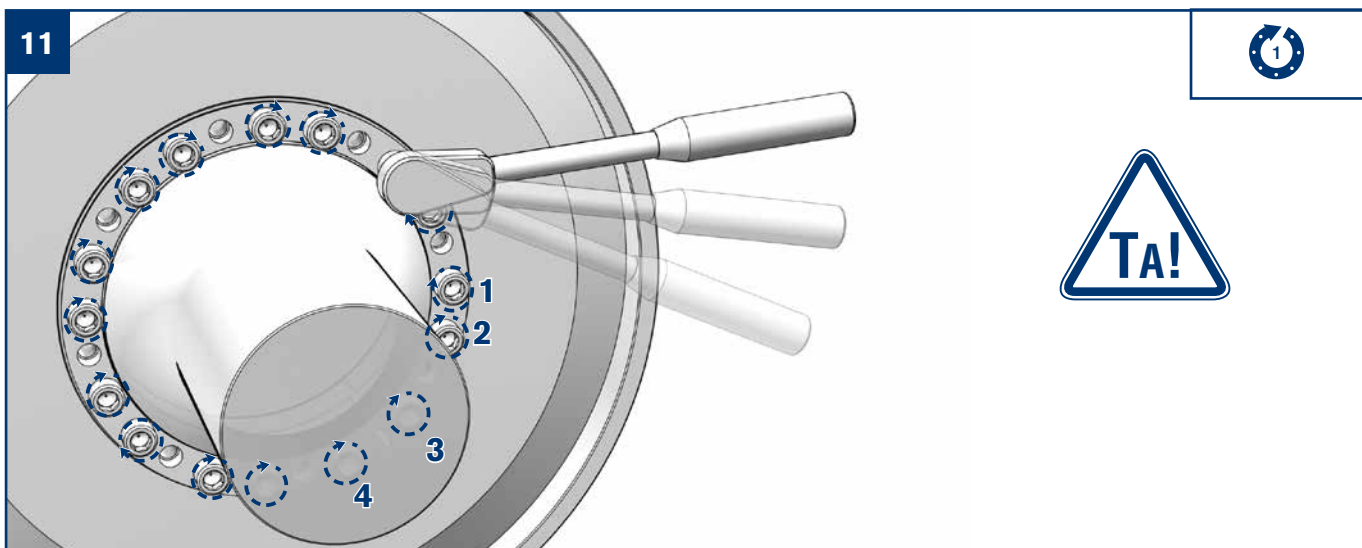
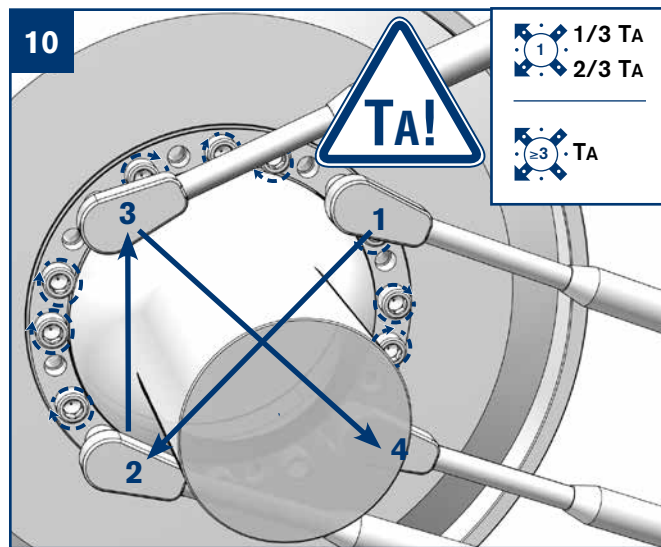
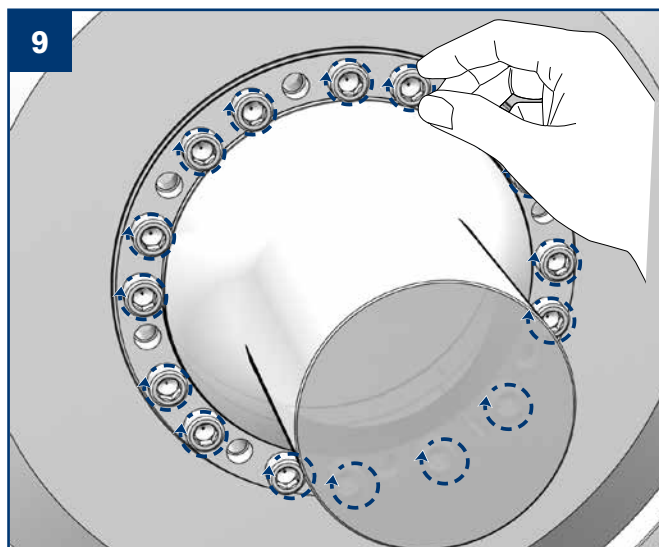
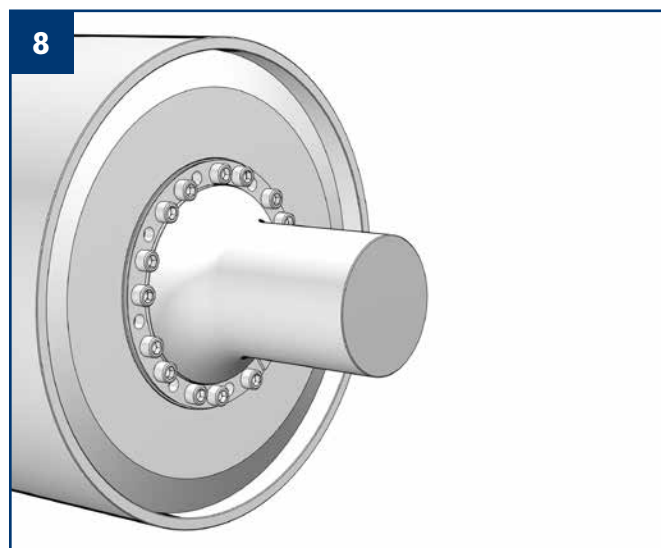
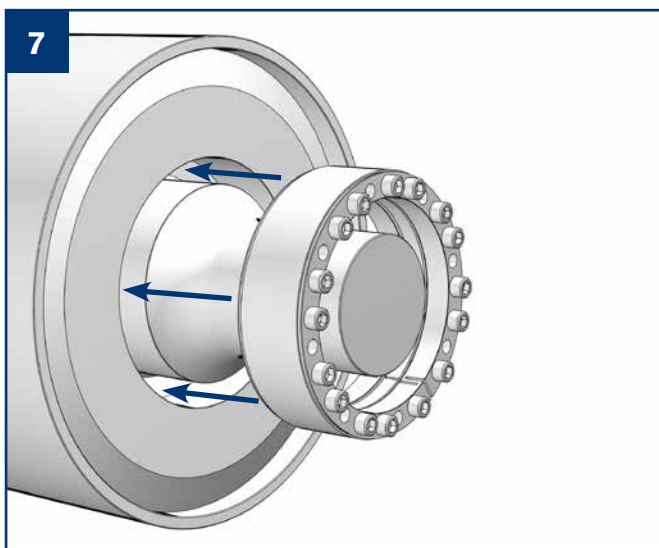



**RINGFEDER POWER TRANSMISSION GMBH**

Werner-Heisenberg-Straße 18, D-64823 Groß-Umstadt, Germany · Phone: +49 (0) 6078 9385-0 · Fax: +49 (0) 6078 9385-100  
E-mail: sales.international@ringfeder.com

**RINGFEDER POWER TRANSMISSION TSCHAN GMBH**

Zweibrücker Straße 104, D-66538 Neunkirchen, Germany · Phone: +49 (0) 6821 866-0 · Fax: +49 (0) 6821 866-4111  
E-mail: sales.tschan@ringfeder.com

**RINGFEDER POWER TRANSMISSION USA CORPORATION**

165 Carver Avenue, Westwood, NJ 07675, USA · Toll Free: +1 888 746-4333 · Phone: +1 201 666 3320 · Fax: +1 201 664 6053  
E-mail: sales.usa@ringfeder.com

**HENFEL INDÚSTRIA METALÚRGICA LTDA.**

Av. Major Hilário Tavares Pinheiro, 3447 · Cer 14871 300 · Jaboticabal - SP - Brazil · Phone: +55 16 3209-3422  
Fax: +55 16 3202-3563 · E-mail: vendas@henfel.com.br

**RINGFEDER POWER TRANSMISSION INDIA PRIVATE LIMITED**

Plot No. 4, Door No. 220, Mount - Poonamallee Road, Kattupakkam, Chennai – 600 056, India  
Phone: +91 (0) 44-2679 1411 · Fax: +91 (0) 44-2679 1422 · E-mail: sales.india@ringfeder.com

**KUNSHAN RINGFEDER POWER TRANSMISSION COMPANY LIMITED**

No. 10 Dexin Road, Zhangpu Town 215321, Kunshan, China  
Phone: +86 (0) 512-5745-3960 · Fax: +86 (0) 512-5745-3961 · E-mail: sales.china@ringfeder.com